

PIEZON[®]

TREATMENT RECOMMENDATIONS



"I FEEL
GOOD"

EMS⁺
MAKE ME SMILE.

AIM OF THIS DOCUMENT

This document aims to provide the users of AIRFLOW® Prophylaxis Master (REF FT-229) with the general precautions and treatment recommendations for use of different EMS PIEZON® Instruments.

For optimum comfort, safety and efficiency of scaling and other procedures, we recommend to integrate the PIEZON® treatment as part of Guided Biofilm Therapy.

The GBT procedure is detailed in our „Treatment Recommendations“ brochure below (Reference FB-648).



Treatment recommendations for AIRFLOW® Prophylaxis Master and AIRFLOW® One

SUMMARY



SCALING.....8



ENDODONTOLOGY16



CAVITY SYSTEMS.....30

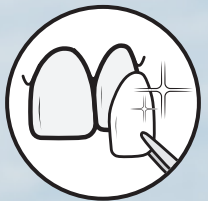

RESTORATION PLACEMENT.....36



•The Treatment Recommendations as well as the Instructions for Use of the devices are provided in electronic format and are part of the product documentation. To receive a hard copy, available free of charge, please order via our website, by telephone or in writing. Allow 7 days for delivery.



•The Treatment Recommendations (document FB-648), as well as the Instructions for Use of the device, are available for downloading in PDF format at ems-instruction.com using the Product/Key Code FT-229 for AIRFLOW® Prophylaxis Master. A PDF reader is required and is available for downloading from the same website.

•It is essential to first read and understand all the Instructions for Use of the device before operating it and using the related accessories. The Treatment Recommendations are an integral part of the device's Instruction for Use. Both documents complement one another.

•We recommend that you visit our website regularly to consult and/or download the latest version of the documentation for your device at ems-instruction.com

•Please contact EMS technical support or your local EMS representative for further information and support.

•Always keep this documentation close at hand.

Always read first the Instructions for Use of any device and refer to those for Intended Use, Intended User, Patient Population, Contraindications, General Precautions and Compatibility. Specific device limitations or deviations may apply.



SYMBOLS



General warning



Water flow level



Wear protective mask



Wash your hands



Electronic instructions for use



Power level



Wear protective glasses



Wear protective gloves

PATIENT PREPARATION:

⚠ PIEZON® treatment is contraindicated for patients with cardiac pacemakers, defibrillators and any implantable electronic device.

START BY RINSING WITH BACTERX® PRO MOUTHWASH.

- !** For your protection and that of your patient, start by rinsing the patient's mouth with BacterX® Pro¹ mouthwash for 20 to 30 seconds.



EMS BACTERX® PRO
0.1% CHLORHEXIDINE
0.08% FLUORIDE

REF:
DV-113 with alcohol
DV-114 without alcohol

- ⚠** Eye protection is mandatory. It is also recommended to remove the patient's glasses and optical lenses. Lip and cheek retractor protection (for example OptraGate) is recommended for maximum patient comfort and improved access.



WEAR PROTECTIVE GLASSES

¹ If available in your country.

DENTIST PREPARATION:

Protect yourself with the following measures:



WEAR PROTECTIVE
MASK



WEAR PROTECTIVE
GLASSES



WASH YOUR
HANDS



WEAR PROTECTIVE
GLOVES

 Most dental procedures involve aerosols which represent a risk for clinician contamination. Ensure that you are effectively vaccinated.



**SWISS
DENTAL
ACADEMY**

For optimum performance, comfort and the latest scientific clinical research, we recommend Swiss Dental Academy training.

PROFESSIONAL PROPHYLAXIS WITH DYNAMIC RESPONSE SYSTEM

From the valley to the top – PIEZON® NO PAIN technology combines legendary Swiss quality and precision workmanship.

ONLY THE COMBINATION OF OUR PERFECTLY MATCHED INSTRUMENTS, HANDPIECES AND MODULES DELIVERS THE SPECIAL “NO PAIN” TREATMENT EXPERIENCE



1. ELECTRONIC
MODULE

2. PIEZON®
LED HANDPIECE

3. SWISS INSTRUMENT PS
– PERIO SLIM

PRECISION ENHANCES COMFORT

1.

→ **PRECISE** AUTO-REGULATION AND DYNAMIC ADJUSTMENT OF THE REQUIRED POWER LEVEL PREVENTS TRAUMATIC PAIN

2.

→ **PRECISE** CONTROL OF LINEAR VIBRATIONS DELIVERS AN UNSURPASSED LEVEL OF PATIENT COMFORT

3.

→ **FINE** WORKMANSHIP OF HIGH-QUALITY SURGICAL STEEL PRODUCES FINELY POLISHED SURFACES



USE ONLY EMS SWISS INSTRUMENTS!

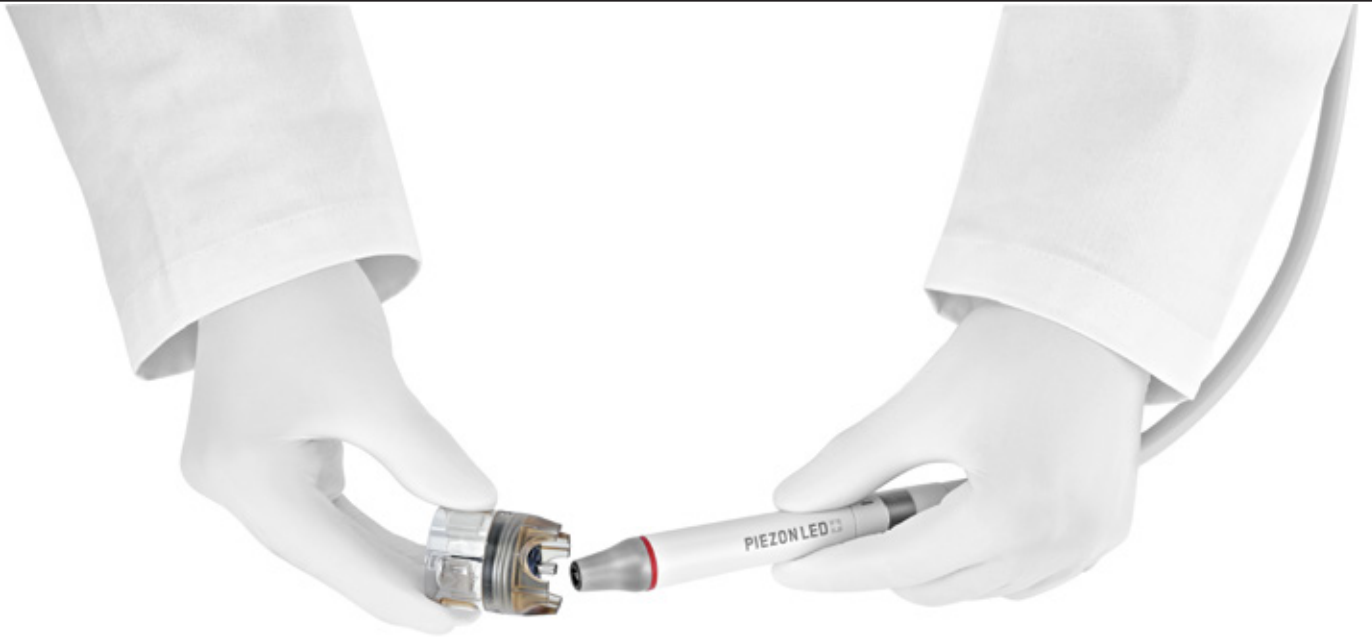

Following the FDI International Dental Federation statement on „Non Compliant Dental Products“, please be aware that EMS devices have been designed and tested for the exclusive use with EMS PIEZON® Instruments.

Using so-called „compatible“ instruments may harm your patient and damage the handpiece connection.

Damage that may result from the use of non-original components is not covered by the EMS warranty.

One single EMS PS Instrument is designed for up to 3000 treatments.

Minimal invasiveness = very limited wear.

Its cost is less than EUR 0.05 per treatment.





SCALING

► After using AIRFLOW®, remove the remaining supra- and subgingival calculus with the PIEZON® NO PAIN* PS Instrument.

**BEFORE
PIEZON®**



**AFTER
PIEZON®**



COURTESY OF PROF. MAGDA MENSI

PIEZON® POWER SETTINGS



► Equipped with NO PAIN® technology, the unit allows for dynamic adjustment depending on the load applied to the instrument.

The following table shows maximum output power per power setting:

PIEZON® Power	Power Setting	0	1	2	3	4	5	6	7	8	9	10
	Max Output Power [W]	0	0.4	1.2	2.1	3.0	3.9	4.8	5.6	6.4	7.2	8.0

⚠ Risk of tip breakage: when using ENDO files, do not exceed power setting 3 (2.5W).

PIEZON® BOOST



► Pressing hard on the center of the wireless pedal activates the BOOST mode and results in increased power, as illustrated in the following table:

PIEZON® Boost	Power Setting	0	1	2	3	4	5	6	7	8	9	10
	Corresponding Boost Level	0	6	7	8	9	10	10	10	10	10	10

⚠ Risk of tip breakage: use BOOST only with tips suited for high power usage. DO NOT use BOOST with ENDO files.

PIEZON® PS INSTRUMENT

UNPARALLELED COMFORT

► Linear movement of the PS Instrument = no damage to the tooth surfaces or soft tissues. Minimally invasive to root cementum. Dynamic power setting.



“I DID NOT REALIZE THAT I WAS BEING TREATED WITH PIEZON®”

A. Tarasconi after his first GBT treatment with PIEZON® NO PAIN PS Instrument.

► EMS PS (Perio Slim) Instrument delivers the best interproximal and subgingival access*.

*CRA, Clinical Research Associates, USA. Newsletter June 1998.

SUPRA- AND SUBGINGIVAL

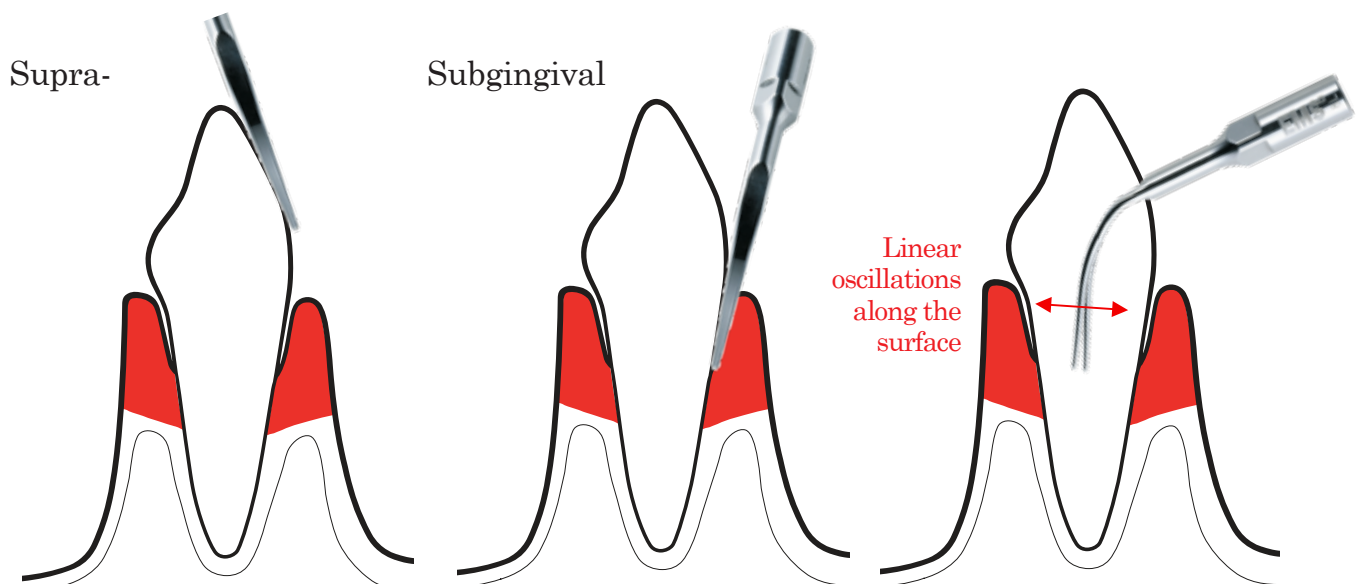

PIEZON® PS INSTRUMENT FOR 95% OF ALL CASES

PIEZON® PS INSTRUMENT SETTINGS

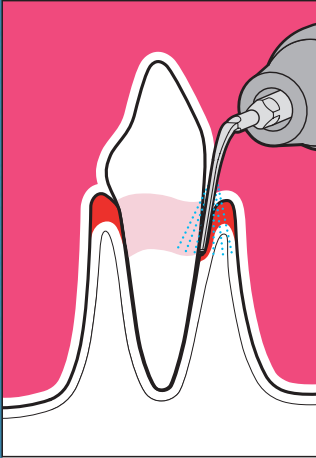

SUPRA- AND SUBGINGIVAL
UP TO 10MM.



30 TO 100%



70 TO 100%



PIEZON® PI INSTRUMENT

EMS PIEZON® PI INSTRUMENT REMOVES BIOFILM AROUND IMPLANT ABUTMENTS AND RESTORATIONS.

- ▶ VERIFY BEFORE USE THAT THE PLASTIC COATING IS NOT WORN OR DAMAGED.
- ▶ THE 120° ANGLED INSTRUMENT IS INCLUDED IN THE PERIOFLOW® APPLICATION BOX. USE ONLY 120° ANGLED INSTRUMENT HOLDER.

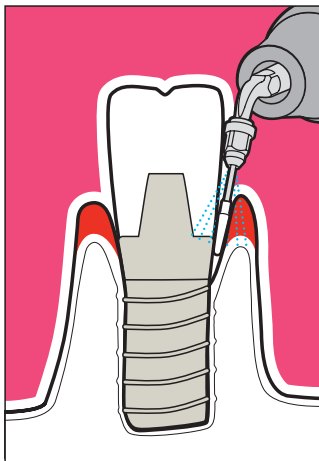

AROUND IMPLANT ABUTMENTS











FS-443 PERIOFLOW® APPLICATION

70 TO 100%
70 TO 100%



PIEZON® SCALING = FEW INSTRUMENTS









► Clinicians initially used to the exclusive use of hand instruments and new to the GBT and EMS PIEZON® scaling in particular, are amazed to find that few instruments are required to cover most clinical cases.

APPLICATION		INSTRUMENT		
HARD CALCULUS SUBGINGIVAL UP TO 4MM		P	30 TO 60%	70 TO 100%
HARD CALCULUS SUPRA ONLY		A	30 TO 60%	70 TO 100%
EASIER LATERAL ACCESS		PL1	30 TO 60%	70 TO 100%
		PL2	30 TO 60%	70 TO 100%
ROOT FURCATIONS AND CONCAVITIES		PL4	30 TO 60%	70 TO 100%
		PL5	30 TO 60%	70 TO 100%

HARD-TO-ACCESS AREAS



► EMS has developed specific instrument shapes to enable debridement in areas that are hard to access.

		NOTE	INSTRUMENT		
Irrigation & disinfection of pockets		Use with antimicrobial solution	PL3 	20 TO 50%	100%
In-depth root debridement using direct vision (flap technique)		Diamond-coated 70 µm	HPL3 	20 TO 50%	100%
Polishing of surfaces that have initially been cleaned and shaped.		After use of HPL3 Diamond-coated 15 µm	DPL3 	20 TO 50%	100%

IN-DEPTH ROOT DEBRIDEMENT

EMS HPL3 INSTRUMENT

- ▶ Within the scope of clinical procedures that use flap techniques.

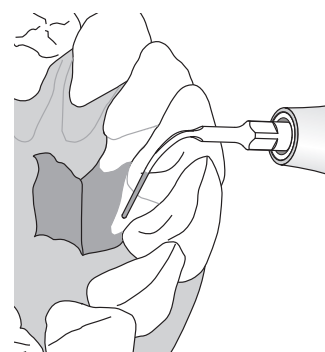
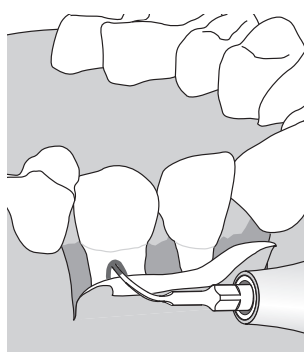
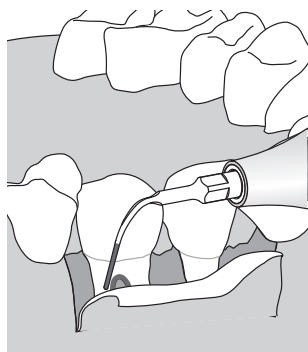

INSTRUMENT



Removal of large deposits

HPL3



10 TO 60%

100%

SPECIFIC INSTRUMENTS FOR THE REMOVAL OF HEAVY DEPOSITS IN SUPRAGINGIVAL AREAS

- ▶ Recommended for large deposits and orthodontic cement residues that require special instrumentation.

EMS B INSTRUMENT

INSTRUMENT



Large deposit removal

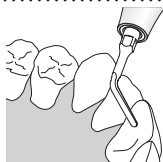

B



50 TO 80%



100%



ENDODONTOLOGY

PIEZON® AND ENDODONTIC APPLICATIONS

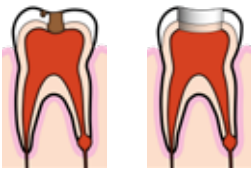
► PIEZON® is recognized for endodontic procedures as a complement to rotary instrumentation. The table below describes step by step the typical endodontic procedures. The added value derived from EMS PIEZON® is described for each step.

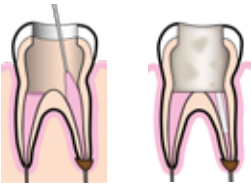
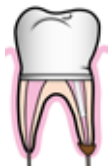
	STEP	APPLICATION	PIEZON® INSTRUMENT
	Initial infection and opening	Crown removal	/
	Infected tissue removal in root canal	Root canal cleaning and irrigation	EMS K-TYPE FILES EMS ES1
		Opening calcified root canal	EMS RT1
		Removal of broken files	EMS RT2 AND RT3
		Retrograde preparation of root canal	EMS BERRUTI AND RE2
	Gutta-percha filling and sealing	Condensation of gutta-percha	EMS H
	Crown cementation		/

PIEZON® ENDO APPLICATIONS

Enhance the quality of treatment and represent an important aid in the treatment of difficult cases. Since their introduction, ultrasonic devices have become increasingly more useful in their applications such as gaining access to canal openings, cleaning and shaping, obturation of root canals, removal of intra-canal materials and obstructions and endodontic surgery. Ultrasonic instruments are a valuable asset for removing intra-radicular posts from root canals before nonsurgical endodontic therapy.

SCIENTIFIC EVIDENCE

Ultrasonics in endodontics: A review of the literature / Journal of Endodontics 2007, 33(2) / Plotino, Pameijer, Grande, Somma

Factors Influencing the Removal of Posts / Stomatologija - Baltic Dental and Maxillofacial Journal 2005, 7(1) / Pečiulienė, Rimkuvienė, Maneliene, Pletkusw

ROOT CANAL CLEANING AND IRRIGATION





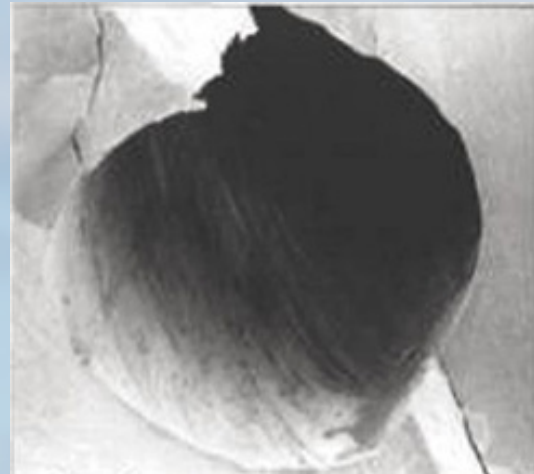
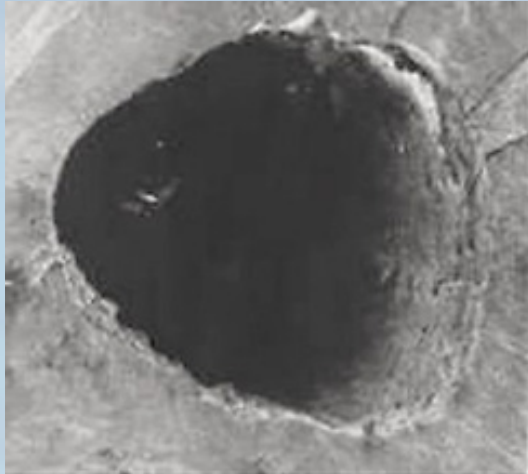





► So-called “EMS compatible” instruments which are not original EMS products present a significantly higher risk of breakage².

USE ORIGINAL EMS INSTRUMENTS ONLY



Comparison between root canal prepared with manual instruments (left) and the PIEZON[®] method (right)³

Place the PIEZON[®]
Instrument on the EMS ENDO CHUCK

INSTRUMENT	 120°	 90°		
 K-TYPE FILES			10 TO 20%	100%
 ESI			10 TO 20%	100%

⚠ Do not use the BOOST mode when using files.

⚠ Never activate the files without irrigation and never operate them outside the root canal to avoid breakage except for 2 sec. during the setting of the irrigation.

⚠ To prevent the files from breaking, create a glide path with a hand endo file and plan for an access as straight as possible to limit the risk of file twisting. Use a light touch-retract motion without rush. Examine the file often to detect any signs of fatigue. As a precautionary measure, replace the file as soon as possible.

² Independent study: “Lack of compatibility was found in 40,35% of all cases (23 of 57 examined combinations).” Resonance compatibility between endosonic tips and ultrasonic devices of different brands. / Journal of IMAB - Annual Proceeding (Scientific Papers) 2014, vol. 20, issue 5/ KK Shiyakov, RI Vasileva.

³ EMS research photo.

PREPARING K-TYPE FILES – ISO 15-35

EMS K-TYPE FILE



► EMS adopted the ISO color code for easier identification⁴.



ISO-	15	20	25	30	35
Ø AT TIP	0.15 MM	0.20 MM	0.25 MM	0.30 MM	0.35 MM
Ø AT 16MM	0.47 MM	0.52 MM	0.57 MM	0.62 MM	0.67 MM
EMS REF	DT-006	DT-007	DT-008	DT-009	DT-010

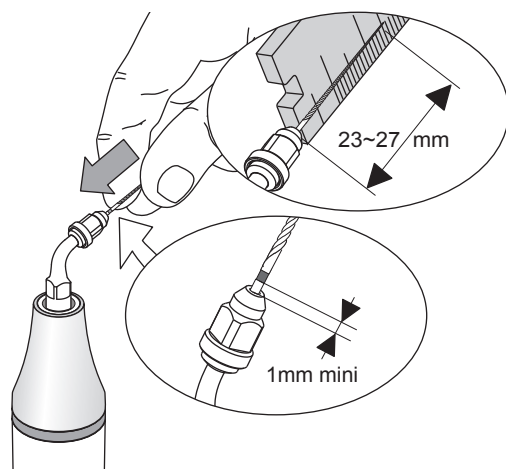

K-type files

⁴ ISO 3630 Dentistry - Endodontic instruments

► The root canal must be prepared using ISO 15 hand files before using K-type files:

1° Mark the file length.

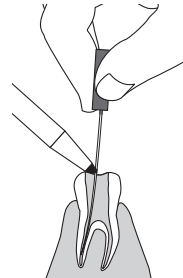

2° Measure.

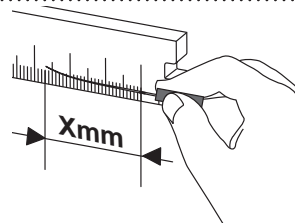

3° Adapt the file length to the file.

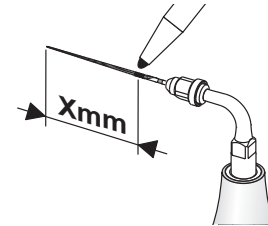

4° Adapt the file form to the canal morphology if needed.

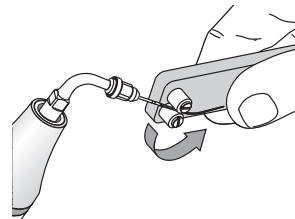

5° To set the flow rate, activate both the irrigation and the ultrasound with the tip pointing upwards. The spray must extend the file tip by 4 mm.



6° ⚠ Activate the file for 4 seconds. Do not exceed 10 continuous seconds. Use slow, circular and up-and-down movements with the „step-back“ technique.

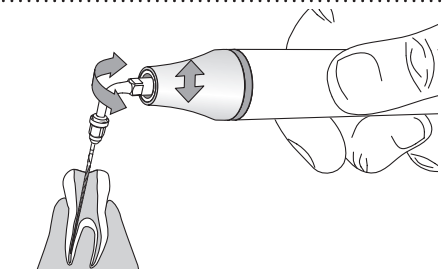

USING ESI FILE

► Root canals can be prepared and then irrigated after k-file ISO 15, using the ESI files with both ultrasonic and rotary handpieces.

PIEZON® ENDO ESI FILE

This is the most efficient agitation mode. At 1 mm from the root apex, the PIEZON® Instrument exhibits the highest score when compared to other techniques.

SCIENTIFIC EVIDENCE

Final rinse optimization: influence of different agitation protocols / Journal of Endodontics 2010, 36(2) / Paragliola, Franco, Fabiani, Mazzoni, Nato, Tay, Breschi, Grandini

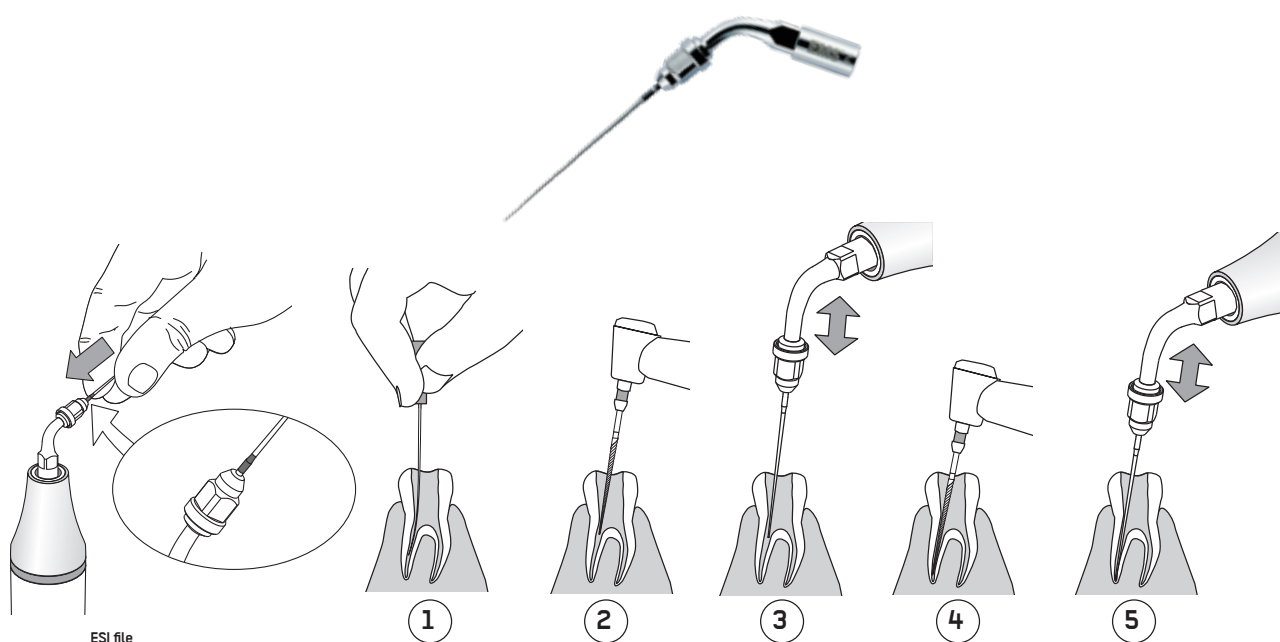

⚠ Smooth non-cutting file made of nickel titanium alloy (NiTi) for cleaning and irrigation of the root canal system. Must be used with a file holder.

Use Endo mode (if available) with a low power setting (maximum 30%) and use a medium to high irrigation flow rate.

⚠ The ESI files can be used in a maximum of fifteen straight root canals, but in one single root canal when it is curved.

The root canal must be prepared using hand files of size ISO 15 before using the ESI file. The ESI file will be used in sequence with a rotating or manual shaping system.



Activate the ESI file for an approximate maximum of 3 x 20 seconds with high irrigation for each canal. Use gentle up-and-down movements to irrigate the root canal.

ROOT CANAL LOCALIZATION AND CALCIFICATION REMOVAL

EMS RT1 INSTRUMENT



- ▶ Chronic irritation or inflammation in the soft tissue of the pulp may cause the pulp to calcify. Ultrasonic endodontic instruments may help to open up a calcified root canal.
- ▶ When the tip vibrates at a very high rate, it creates miniature sound waves that break up the calcification.

		
Root canal localization	20 TO 50%	100%
Calcification removal in the first coronal third of the root system.	20 TO 50%	100%

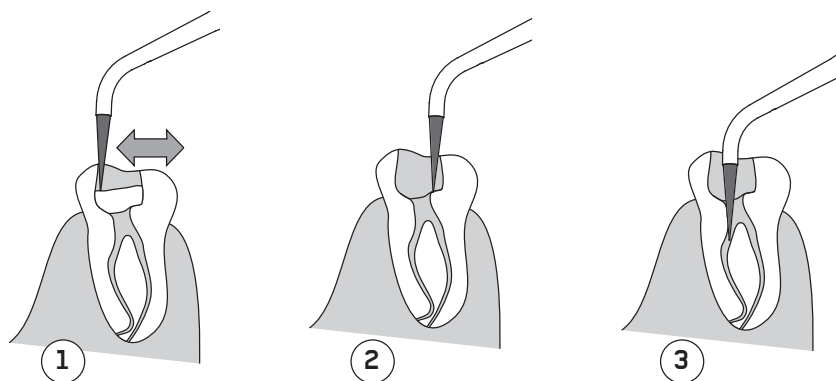

 Remove the calcification without applying pressure.

DIAMOND-COATED INSTRUMENTS



Example of an PIEZON® RT1
Instrument with diamond coating

- ⚠ The diamond-coated instruments are very efficient. Always use with sufficient irrigation flow to avoid damaging hard and soft tissues and to reduce wear.
- ⚠ The ultrasound vibrations cannot be delivered properly when the tip of the instrument is under heavy load. A gentle pressure on the instrument will release its full effective power without the risk of tissue damage and enable a noteworthy reduction of wear.
- ⚠ Visually inspect the diamond coating before use.
Worn coating greatly reduces the efficiency.





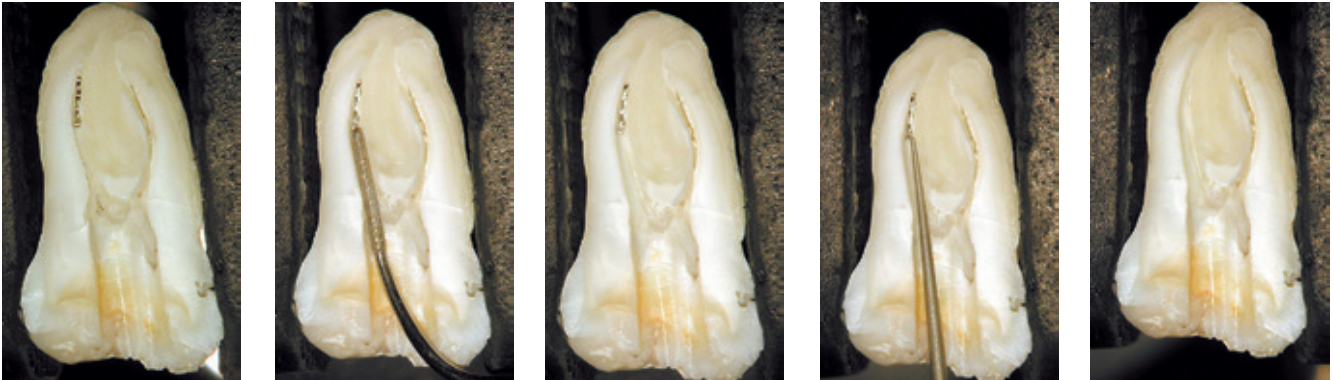

REMOVAL OF BROKEN FILES

► Files may fracture off in the canal space, whether due to root shape, excessive force or metal fatigue. The ability to effectively remove broken file fragments is a significant advantage for the practitioner when tooth preservation is at stake⁵.

EMS RT2 (LEFT) AND RT3 (RIGHT)



⚠ Do not make contact between instrument and broken file in order not to push it deeper. Do not apply pressure to the instrument in the axial direction.

	EMS ENDO CHUCK NEEDED	INSTRUMENT		
Remove ledges (shoulders) and other obstacles	No	RT2 	10 TO 20%	100%
Create straight canals to broken instrument	No	RT2 	10 TO 20%	100%
Remove broken file parts from the root canal		RT3 	10 TO 20%	100%

⁵ Use the ESI file to finish the root canal following the removal of the broken file.

K-FILE OFF-LABEL USE CLINICAL CASE REPORT

► Scientific literature reports cases of outstanding removal of broken instrument with K-files, due to their extremely small diameter. EMS reports that this is outside the intended use of K-files and that these excellent results are to be mitigated by the higher risks of breakage.

SCIENTIFIC EVIDENCE

When compared to 7 other files from different brands, the K-file 25 demonstrated greater speed, higher efficiency (80%) and the smallest diameter .

The Effectiveness in the curve of eight types of endosonic tips for broken instrument removal / Journal of IMAB - Annual Proceeding (Scientific Papers) 2014, 20(5) / Shiyakov, Vasileva⁶

USING RT2⁷

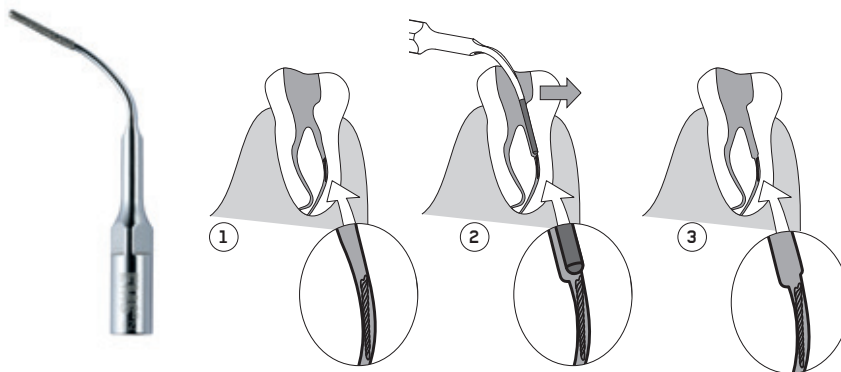

USING RT3



► If possible, place the patient head in a position where the root canal is horizontal with a downward inclination. Rotate the tip of the instrument counterclockwise around the broken part until it is free from the root canal.

► The combined effect of irrigation flow and gravity enables the broken file and debris to be extracted from the root canal. Avoid contact between instrument and broken file in order not to push it deeper.

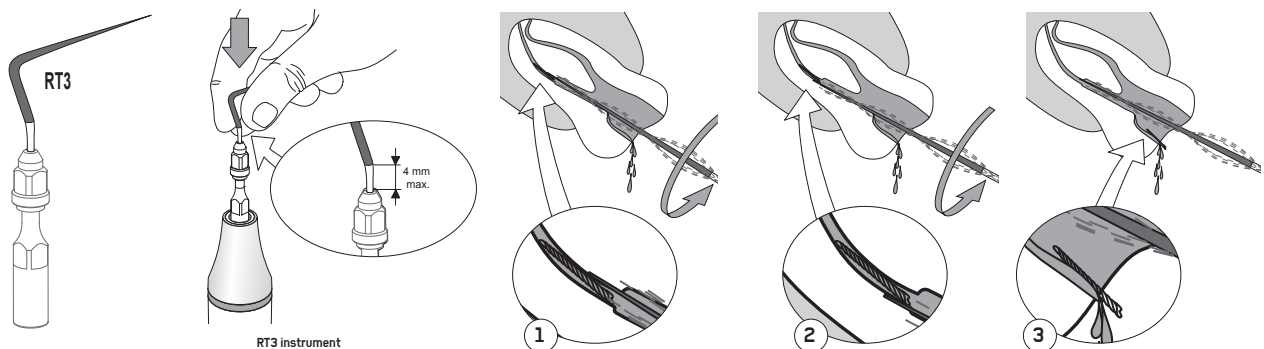

⁶ In this study, the so-called RT3 EMS instrument was not an EMS instrument (identification obvious due to tip color).
⁷ Following procedure of Doctor Merino, Spain.

ROOT FILLING



EMS H INSTRUMENT



gutta-percha

Thermal condensation of gutta-percha:

► Once the infected pulp tissue has been removed, the practitioner fills the decontaminated canal with an inert filling. The standard filling material is gutta-percha, which is injected to fill the root canal passage.

			
.....			
Lateral condensation of the root canals.	gutta-percha in	20 TO 50%	0%

► The heat generated by the ultrasound causes the instrument to liquify the gutta-percha.

⚠ Irrigation is not needed due to a cooling effect.

1° Immerse the instrument in eugenol before inserting in the canal.

2° Slightly press the instrument against the cone of gutta-percha.

3° Activate the ultrasound for 2 seconds to condense.

4° Repeat for each inserted cone...

5°... until the canal is filled.

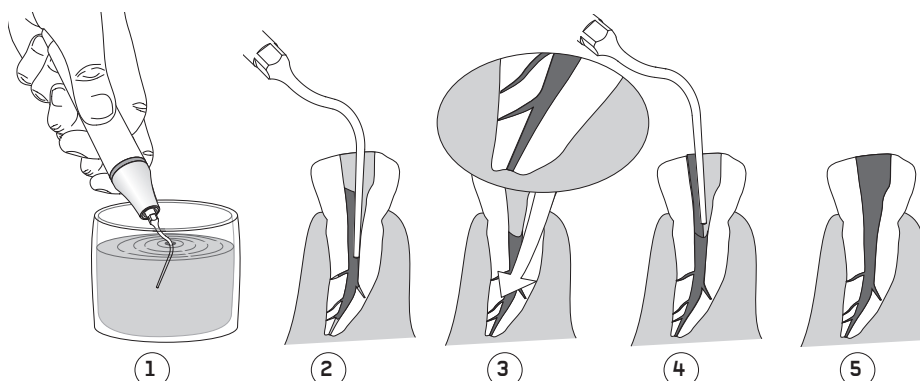

CROWN REMOVAL

EMS D INSTRUMENT



- ▶ Loosening the cement that attaches crowns and bridges to the tooth.
- ▶ When a tooth, restored with a crown, requires endodontic treatment, the practitioner may choose to remove the restoration. Removal often facilitates endodontic treatment especially if the procedure is atraumatic for the patient and time-saving for the practitioner.

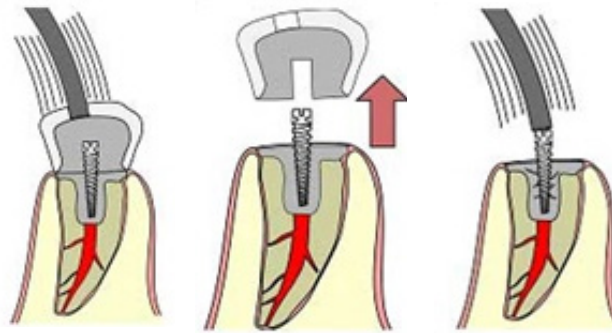

1°  Works on cements with mechanical or micro-mechanical retention.

It does not work on adhesive bonded cements.

2° Apply the instrument to the surface and activate.

3° Increase the pressure until vibrations can no longer be heard and maintain for few seconds.

An intermittent activation avoids injuring the pulp due to heat by allowing time for heat dissipation.

 The instrument D is useful for loosening cementation on hard materials.

However, the high frequencies of ultrasound applied to ceramics or composites may eventually fracture them.

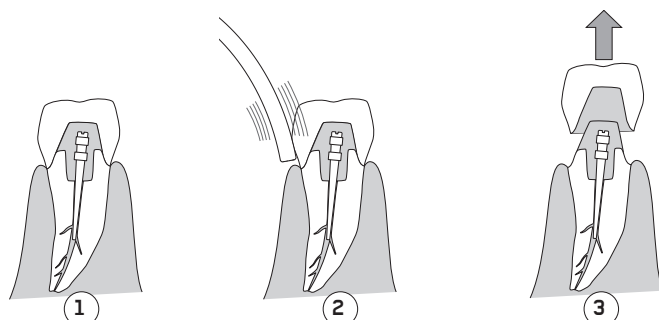

RETROGRADE PREPARATION OF ROOT CANAL

EMS BERUTTI INSTRUMENT



- ▶ 2mm diamond-coated for increased cutting efficiency and less risk of micro-fractures
- ▶ Instruments can be pre-bent
- ▶ Optimum visibility with the use of 120° or 180° Endochuck

SCIENTIFIC EVIDENCE⁸

Ultrasonic EMS retro instrument removed less dentine than laser instruments.

EMS retro tip with the EMS Berutti instrument showed a better score for quality of preparation when compared to other competitor ultrasonic and laser instruments. Root end cavities should be prepared with ultrasonic tips.

The cavity was prepared for retrograde filling using an EMS PIEZON[®] device and instrument.

An in vitro evaluation of apicoectomies and retropreparations using different methods. *Oral Surg Oral Med Oral Pathol Oral Radiol Endod.* 2010,110(4) Camargo Villela Berbert, de Faria-Júnior, Tanomaru-Filho, Guerreiro-Tanomaru, Bonetti-Filho, Leonardo Rde, Marcantonio

Evaluation of ultrasonic and ErCr:YSGG laser retrograde cavity preparation. / *Journal of Endodontics* 2009, 35(5) Batista de Faria-Junior, Tanomaru-Filho, Guerreiro Tanomaru, de Toledo Leonardo, Camargo Villela Berbert

A prospective clinical study of polycarboxylate cement in periapical surgery / *Med Oral Patol Oral Cir Bucal.* 2012,17(2) / Peñarrocha-Diago, Ortega-Sánchez, García-Mira, Maestre-Ferrín, Peñarrocha-Oltra, Gay-Escoda

⁸ "All root-end cavities were done setting the ultrasonic device unit at no more than half power, 26-27 under constant copious sterile water irrigation to avoid overheating." In *Endodontic surgery with ultrasonic retrotips: One-year follow-up*/ S Taschieri, M Del Fabbro, T Testori, L Francetti, R Weinstein/ *Oral Surg Oral Med Oral Pathol Oral Radiol Endod* 2005;100:380-7.

NOTE

INSTRUMENT



Preparation of the root canal allowing for cutting inside the tooth structure

Retrograde
Diamond-coated

BERUTTI

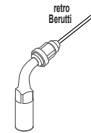

20 TO 50%

20 TO 60%

1° The instrument can be bent once for easier access to the canal. A second bend would break the instrument.

2° Keep the cut of root apex and bone cavity as small as possible.

3° The use of retrograde instruments requires much less space than when using conventional files.

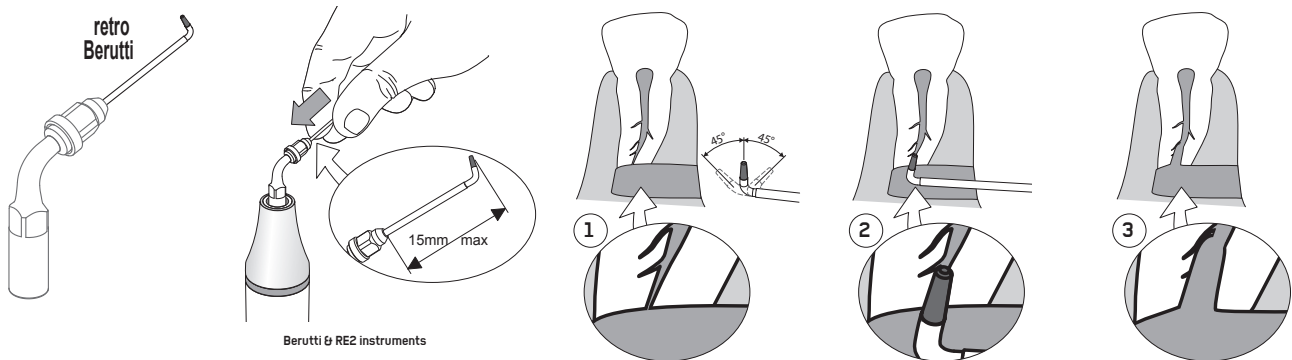

ISTHMUS RETROGRADE PREPARATION

EMS RE2 INSTRUMENT



- Non-abrasive titanium alloy-coated instrument for optimal preparation of isthmus.

NOTE

INSTRUMENT



Idem, thinner.

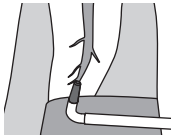

Titanium Nitride
Retrograde
Use with file holder

RE2

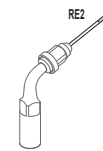

20 TO 50%

10 TO 60%

- Perform a full retrograde canal preparation prior to isthmus preparation.

1° The use of retrograde instruments requires much less space than when using conventional files or instruments.

2° Insert the instrument in one of the two canals where the isthmus begins then gently move it along the isthmus to create a small groove.

3° Keep the cut of root apex and bone cavity as small as possible.

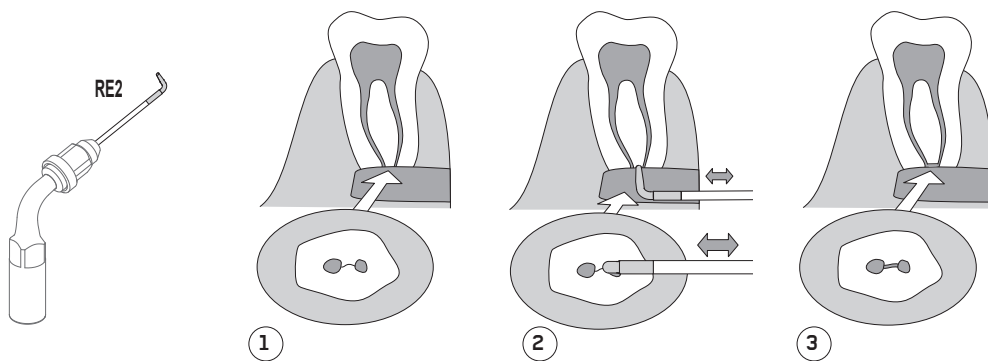



CAVITY SYSTEMS

► The PIEZON® CAVITY SYSTEMS have been developed to provide a minimally invasive solution and high-precision finishing tool for cavity preparations.

CARIES APPROXIMAL TREATMENT, PRESERVING THE ADJACENT TOOTH

EMS INSTRUMENTS SM AND SD FOR PRESERVATION OF THE ADJACENT TOOTH.









EMS SM Instrument



EMS SD Instrument

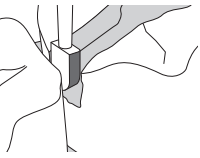

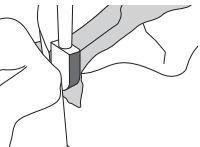
Left: Interdental cavity
Right: After preparation

		NOTE	INSTRUMENT		
Prepare distal and mesial cavities without damaging the adjacent tooth.		Diamond-coated	SD 	20 TO 50%	100%
Prepare distal and mesial cavities without damaging the adjacent tooth.		Diamond-coated	SM 	20 TO 50%	100%

All preparations were performed with a low-pressure application of the handpiece.

► Introduce the instrument from the occlusal side into the cavity and slowly move the instrument up and down to prepare the cavity. Apply low pressure.

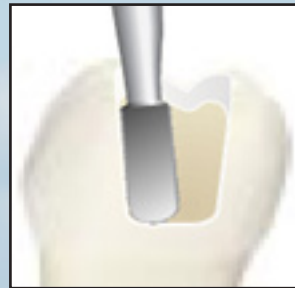
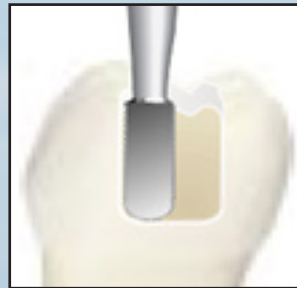
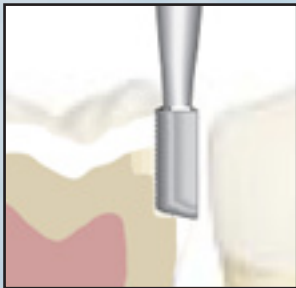
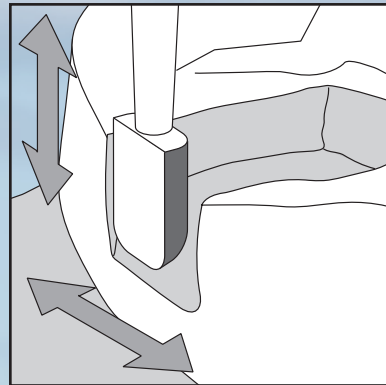
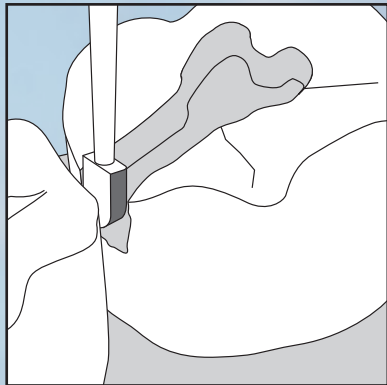

Composite

Inlay

Amalgam

MICRO PREPARATION OF CAVITIES AND FINISHING OF CAVITY MARGINS

EMS SB SBM AND SBD INSTRUMENT





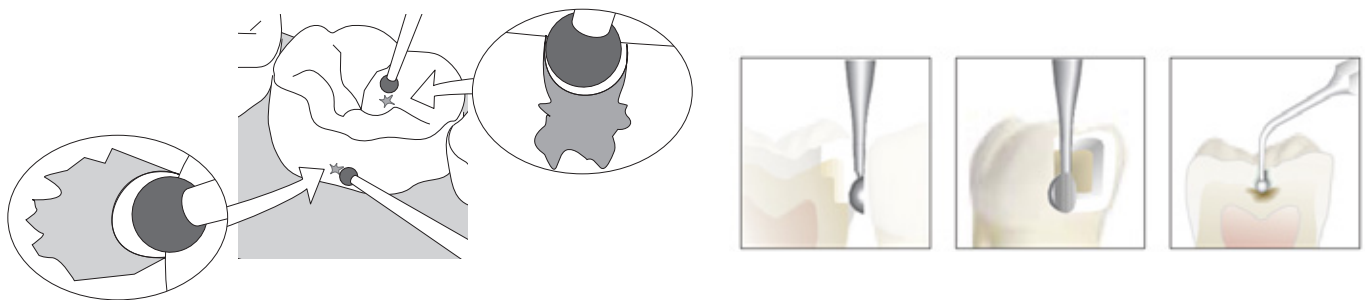

► Place the instrument on the pit and slowly move with light pressure.



SCIENTIFIC EVIDENCE

“Oscillating, selectively coated diamond instrument (i.e. PIEZON® Cavity System, EMS...) may facilitate the preparation of the cavity in the interproximal surface”.

Bonded indirect restoration for posterior teeth: From cavity preparation to provisionalization / Quintessence International 2007, 38(5) / Rocca, Krejci

	NOTE	INSTRUMENT		
Open pits and small caries.	Diamond-coated	 SB	20 TO 50%	100%
Bevel and finish mesial and distal cavity margins.	Diamond-coated	 SBd	25%	100%
Bevel and finish mesial and distal cavity margins.	Diamond-coated	 SBm	50%	100%

PREPARATION OF VENEERS AND ENLARGING FISSURES BEFORE SEALING

EMS VE INSTRUMENT

VE instrument with 1 side diamond-coated edge preserves the adjacent tooth in veneer preparations.

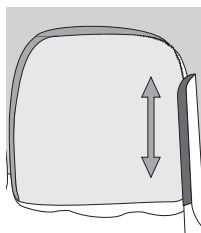
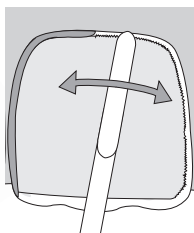

NOTE

INSTRUMENT



Prepare the tooth for placement of veneers.

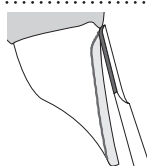

Diamond-coated

VE



20 TO 50%

100%

► Place the instrument parallel to the surface or on the interproximal limits and move it along the edges while applying a medium pressure.

EMS PF INSTRUMENT

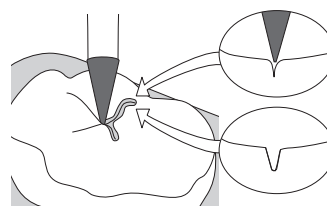

► Diamond-coated instrument for the preparation of preparing fissures and pits (fissurotomy). Place the instrument at the fissure site and move it along with light pressure.

NOTE

INSTRUMENT



Clean and enlarge fissures before sealing.

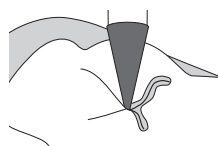

Diamond-coated

PF



20 TO 50%

100%



RESTORATION



Use of PIEZON® SP Instrument for margin sealing in restorations¹².

PIEZON® SP INSTRUMENT APPLICATIONS

“to position and seat the restorations while using an EMS plastic ultrasonic tip to help vibrate out the excess cement for a more complete seal of the margins.”

“The thineers were luted using an ultrasonic device (EMS ; Nyon, Switzerland) with a modified rubber tip (SP-Tip, EMS).”

In restoration, PIEZON® SP Instrument can improve marginal quality of the cavities.

SCIENTIFIC EVIDENCE

The Biomimetic Smile Makeover: Conserving and Strengthening Tooth Structure While Transforming A Smile / CDEWorld 2015 / Lazare

From Veneers to Thineers: Two Case Reports with three years follow up / IOSR Journal of Dental and Medical Sciences 2013,11(2) / Mangat, Podar, Miglani

Influence of Beveling and Ultrasound Application on Marginal Adaptation of Box-only Class II (slot) Resin Composite Restorations / Operative Dentistry 2007, 32(3) / Schmidlin, Wolleb, Imfeld, Gyax, Lussi

INSTRUMENT



Place and cement inlays, onlays & veneers

SP



10 TO 20%

0%

¹² M Lazare 2015.

PLACEMENT

With a highly thixotropic dual-curing composite cement.

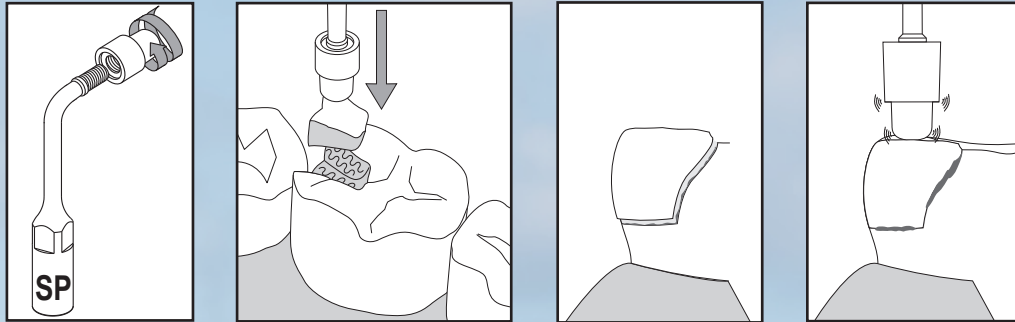

- ▶ Screw the cap onto the instrument and tighten it finger tight. Position the inlay or onlay in its final seating position without exerting pressure on the instrument. The composite cement returns to solid state as soon as the ultrasound activation is stopped.
 - ▶ The caps wear during use and must be replaced once the threads are no longer tight or when the cap surface shows wear.
- ⚠** We recommend the use of a rubber dam to prevent the patient from accidentally swallowing or inhaling parts or debris. When a rubber dam cannot be used, instruct the patient to breathe through the nose.

FROM THE VALLEY

► For more than 35 years EMS has developed high-end technologies and protocols in conjunction with the world's most advanced clinicians, enabling the patients to enjoy natural teeth and implants for much longer.

„Primum non nocere“ * and minimal invasiveness are not only a must, they are our way of life.

* „First do no harm“ from the Hippocratic Oath.

EMS RESEARCH AND MANUFACTURE CENTER
NYON, SWITZERLAND



TO THE TOP

MONT BLANC, 4807M















CONTACT US:
ems-dental.com/contact
T. +41 22 99 44 700
F. +41 22 99 44 701

SETTINGS

► The setting recommendations of the present document apply to AIRFLOW® Prophylaxis Master.

► The following table may help users to find corresponding settings for older EMS devices.

AIRFLOW DEVICES:	PROPHYLAXIS MASTER AND AIRFLOW ONE	MASTER PIEZON	S2
	EN-060 EN-061	EN-060 EN-061	/ EN-046
 100%	10	17 LED	
 50%	5	9 LED	
 10%	1	1 LED	
 100%	10	11 LED	
 50%	5	6 LED	
 10%	1	1 LED	

EMS WORLDWIDE

HEADQUARTERS

 **ON, SWITZERLAND**
E.M.S. ELECTRO MEDICAL SYSTEMS S.A.
Chemin de la Vuarpillière 31
CH-1260 Nyon
ems-dental.com/contact
T. +41 22 99 44 700
F. +41 22 99 44 701

WORLDWIDE EMS AFFILIATES

MUNICH, GERMANY
EMS ELECTRO MEDICAL SYSTEMS GMBH
Schatzbogen 86
D-81829 München
Tel. +49 89 42 71 61 0
Fax +49 89 42 71 61 60
e-mail: info@ems-ch.de

PARIS, FRANCE
**EMS ELECTRO MEDICAL SYSTEMS
FRANCE SARL**
23, avenue Louis Breguet
Immeuble Santos Dumont, Batiment D
F-78140 Vélizy-Villacoublay -
France
Tel. +33 1 34 58 03 80
e-mail: info@ems-france.fr

MADRID, SPAIN
**EMS ELECTRO MEDICAL SYSTEMS
ESPAÑA SLU**
C/ Tomás Bretón, 50-52 2ª planta
E-28045 Madrid
Tlf. +34 91 528 99 89
e-mail: info@ems-espana.com

MILANO, ITALY
EMS ITALIA S.R.L
Via Faravelli 5
I-20149 Milano
Tel. +39 02 3453 8111
e-mail: dental@ems-italia.it

! CONTACT EMS

If any serious incident occurs that is directly or indirectly related to the treatment, report it immediately to EMS and to the competent authority of your country and that of your patient's place of residence (if different).

ADVERSE EVENT NOTIFICATION :
vigilancemailbox@ems-ch.com

GENERAL SUPPORT:
ems-dental.com/contact
TSAV@ems-ch.com

SHANGHAI, CHINA
医迈斯电子医疗系统贸易(上海)有限公司
**E.M.S. ELECTRO MEDICAL SYSTEMS TRADING
(SHANGHAI) CO., LTD.**
24A, Jin Sui Mansion,
N°379 Pudong Nan Rd.
Shanghai, China 200120
Tel. +86 21 3363 2323
e-mail: emschina@ems-ch.com

DALLAS, USA
EMS CORPORATION
11886 Greenville Avenue, Ste. 120
Dallas, Texas 75243
United States of America
Phone : +001 972 690 8382
Fax : +001 972 690 8981
E-mail : info@ems-na.com

TOKYO, JAPAN
E.M.S. JAPAN BRANCH OFFICE
501, 73 Kanda Neribeicho
Chiyoda-ku
Tokyo 101-0022 - Japan
Phone : +81 (0) 3 5207 6795
Fax : +81 (0) 3 5207 6796
E-mail : emsjapan@ems-ch.com

GET STARTED

"I FEEL GOOD"

Copyright: 2018 EMS.
E.M.S. Electro Medical Systems S.A.
Ch. de la Vuarpillière 31
1260 Nyon - Switzerland
+41229944700 - ems-dental.com

EMS 
MAKE ME SMILE.